



THE TIME & TEMPERATURE COMPANY®

Model: INTP662

## ProAccurate® Infrared Gun/ Thermocouple Thermometer

Infrared: -76 to +662°F/-60 to +350°C

Thermocouple: -76 to +662°F/-60 to +350°C

for non-contact and internal temperatures

- NSF® Certified
- 1 & 3 second responses
- 1.5 mm thin tip
- 3.75" (9.53 cm) probe
- Infrared for non-contact surface temperatures
- Thermocouple probe for internal temperatures
- Dual function
- Maximum, minimum and lock modes for continuous scanning
- 8-beam laser target illumination
- Distance:Spot = 8:1
- Data-hold
- One-button operation
- Backlit HACCP check lights
- Battery status indication
- Food-safe ABS plastic with BioCote®
- Stainless steel probe
- Auto-off
- Battery and instructions included

## Get Professional Results Every Time!

Monitoring temperature is essential to keeping food safe. The versatile INTP662 is a powerhouse kitchen tool. Simply point the infrared gun toward the target and press the trigger to get a quick reading of surface temperatures or flip down the rapid-response thermocouple probe to measure internal temperatures. Integrated HACCP check backlighting instantly shows if temperatures are within HACCP guidelines for safe food temperatures.

### Minimum, Maximum and Lock

The INTP662 also offers Minimum, Maximum, and Lock modes. Minimum mode displays the lowest temperature among multiple targets. Maximum mode displays the highest temperature among multiple targets. While Lock mode continuously displays the temperature for up to 60 minutes. This is particularly useful for continuous temperature monitoring.

**Note:** Remove sticker from display before use. Clean the thermometer probe before each use.

**Important: DO NOT LEAVE THERMOMETER IN HOT OVEN. HAND WASH AND DRY. DO NOT IMMERSE HOUSING IN LIQUID.**

**Note:** In the following instructions, names of the control buttons are shown in CAPS. Function information that appears on the display is shown in **BOLD CAPS**.

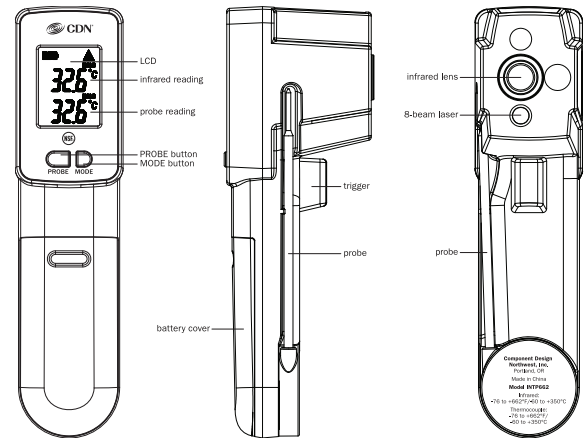

## Battery Installation

Replace battery when LCD becomes dim. Power off the unit before installing the batteries. A malfunction may occur if the power is on when the battery is installed. If a malfunction occurs, restart the device.

1. Remove battery cover by sliding it down along the handle.
2. Install two 1.5V AAA batteries observing polarity shown in compartment.
3. Replace the battery cover until it clicks shut.



# Operating Instructions

**Mode Selection:** MIN > MAX > LOCK > °C/°F > EMIS

## A. Temperature Scale

To select temperature reading in Fahrenheit or Celsius:

1. Press the trigger to turn the thermometer on.
2. Press the MODE button four times. The °F or °C symbol flashes on the display.
3. Press the SCAN button to change the scale.

## B. Infrared Thermometer

Infrared is the default mode of the INTP662.

**Note:** The INTP662 is intended for food service use — do not use for safety related applications.

### 1. Infrared Scanning

#### a. Distance:Spot = 8:1

For example, if the surface area being measured is 10" in diameter, then the thermometer must be within 80" of the target for an accurate reading.

Distance:Spot (FOV) = 8:1 Emissivity = 0.1~1, Step .01 Wave Length = 8~14µm
---

- b. Aim the infrared lens at the target and press the trigger to display the surface temperature. The 8-beam laser light automatically illuminates the target, specifying the approximate measurement area for better targeting.
- c. The 8-beam laser light forms a circle that defines the area of measure. Make sure the circle is smaller than the area being measured. If the laser light circle is larger than the area being measured, the reading will include ambient temperatures and make the reading inaccurate.
- d. Measurement continues as long as the trigger is pressed. The newest reading updates the display.
- e. When the trigger is released, **HOLD** appears on the display and the last reading remains visible for 15 seconds before the unit automatically powers off.

### 2. Minimum Mode

- a. Press the trigger to turn the thermometer on.
- b. Press the MODE button once. **MIN** flashes on the display.
- c. Press the trigger to confirm the Minimum Mode and display the lowest temperature among multiple targets. **MIN** remains on the display.
- d. The thermometer continues to display the minimum reading during each measurement period until the MODE button is pressed again or the unit powers off.

### 3. Maximum Mode

- a. Press the trigger to turn the thermometer on.
- b. Press the MODE button twice. **MAX** flashes on the display.
- c. Press the trigger to confirm the Maximum Mode and display the highest temperature among multiple targets. **MAX** remains on the display.
- d. The thermometer continues to display the maximum reading during each measurement period until the MODE button is pressed again or the unit powers off.

### 4. Lock Mode

This is particularly useful for continuous temperature monitoring.

- a. Press the trigger to turn the thermometer on.
- b. Press the MODE button three times. **LOCK** flashes on the display.
- c. Press the trigger to confirm the Lock Mode. The °F or °C symbol flashes on the display.
- d. The thermometer continuously displays the temperature for up to 60 minutes or until the trigger is pressed again.

### 5. Emissivity

Everything gives off a certain amount of radiation. Emissivity is the measure of this thermal radiation. The infrared thermometer is supplied with a default emissivity of 0.95, which standard for most uses. The emissivity of the thermometer can be changed from 0.10 (10E) to 1 (100E). **Only experienced personnel should attempt to make changes.** For information relating to the emissivity of specific materials, please contact CDN.

- a. Press the trigger to turn the thermometer on.
- b. Press the MODE button five times to enter Emissivity Mode. **95E** flashes on the display.
- c. Press the trigger to adjust the emissivity value in 0.01 (1E) increments.
- d. Press the MODE button again to exit Emissivity Mode.

**Note:** Non-contact infrared thermometers are not recommended for use in measuring the temperature of shiny or polished metals.

### 6. Error Messages

The INTP662 incorporates visual diagnostic messages as follows:

- a. **HI** or **LO** is displayed when the temperature being measured is outside the infrared range of the instrument.

**Hi**

1.) **HI** indicates that the temperature is higher than +662°F/+350°C.

**Lo**

2.) **LO** indicates that the temperature is lower than -76°F/-60°C.

- b. Allow a minimum 30 minutes for the thermometer to stabilize to the working/room temperature.

**CAUTION: Never point the unit and/or laser towards anyone's eyes. Do not look directly into the laser beams — permanent eye damage may result. Keep away from children.**

- Er 2** 1.) **ER2** is displayed when the thermometer is exposed to rapid changes in the ambient temperature.
- Er 3** 2.) **ER3** is displayed when the ambient temperature exceeds -32°F/0°C OR +122°F/+50°C.
- Er** c. For all other error messages it is necessary to reset the thermometer.
- 1.) Wait for the thermometer to power off.
  - 2.) Remove the battery and wait for a minimum of one minute.
  - 3.) Reinstall the battery (see **Battery Installation**).
  - 4.) Press the Trigger to turn the thermometer on.
  - 5.) If the error message remains, please contact CDN for further assistance.

### C. Thermocouple Probe

**Important: The probe may be damaged if measurement temperature is lower than -76°F/-50°C OR higher than +662°F/+350°C.**

1. Flip down the probe until fully extended.  
**Important: Do not twist the probe or rotate it in wrong direction. Exceptional stress on probe may cause it to break.**  
**CAUTION:** To avoid electric shock and thermometer damage, do not use the thermocouple probe to measure live circuit where voltage exceeding 24V AC RMS or 60V DC.
2. Insert the probe at least 1"/2.5 cm into the food.
3. Press the PROBE button to continuously display the temperature for up to 4 minutes before the unit automatically powers off. The display flashes.  
**Note:** Pressing the PROBE button may interrupt the last infrared HOLD reading. Press the PROBE button again to return to infrared scanning.
4. Wearing a heat resistant glove, flip the probe back into the case when finished.  
**CAUTION:** Probe may be HOT after use. Always wear a heat resistant glove to touch the stainless steel probe during or just after cooking. **Do not touch with bare hands.**
5. Press the PROBE button again to return to infrared scanning.

### D. HACCP Check



Integrated HACCP check backlights instantly show if temperatures are within HACCP guidelines for safe food temperatures.

**Note:** The GREEN and RED LED backlight will always be lit before power off.

1. A **GREEN** LED backlight indicates a safe cool or frozen condition below 40°F/4°C or a safe holding temperature above 140°F/60°C.
3. A **RED** LED backlight indicates that the temperature is within the **HACCP Danger Zone** of 40 to 140°F/4 to 60°C.

### E. Battery Status

The thermometer incorporates visual battery status indication:

1.  **Battery OK:** measurements are possible
2.  **Battery Low:** replace battery with two 1.5V AAA Alkaline cells; measurements are possible
3.  **Battery Exhausted:** replace battery; measurements are not possible

## EMC/RFI

Readings may be affected if the unit is operated within a radio frequency electromagnetic field strength of approximately 3 volts per meter, but the performance of the instrument will not be permanently affected.

## Care of Your Product

- The sensor lens is the most delicate part of the thermometer and should be kept clean at all times. Take care when cleaning the lens. Use only a soft cloth or cotton swab with water or rubbing alcohol. Allow the lens to dry fully before using the thermometer.
- Do not submerge any part of the thermometer in water. Wipe clean with a damp cloth.
- Store the thermometer at room temperature between -4 to +149°F/-20 to +65°C.

## Precautions

- Dispose of used battery promptly and keep away from children.
- Always wear a heat resistant glove to touch the stainless steel probe during or just after cooking.  
**Do not touch with bare hands.**
- Keep the batteries, stainless steel probe and laser away from children.
- Clean the probe and dry thoroughly after use.
- Do not clean the case with abrasive or corrosive compound, which may scratch the plastic and corrode the electronic circuits.
- Do not subject the unit to excessive force shock, dust, temperature or humidity, which may result in malfunction, shorter electronic life span, damaged battery and distorted parts.
- Do not tamper with the unit's internal components. Doing so will invalidate the warranty on the unit and may cause unnecessary battery damage and distorted parts.
- Do not subject the unit to excessive exposure to direct sunlight. **The unit is not waterproof** – do not immerse it into water or expose to heavy rain.
- To avoid deformation, do not place the unit in extreme temperatures. Never burn the probe directly over the fire. Do not use the probe when the temperature is above 662°F/350°C. Doing so will deteriorate the probe.
- Do not use the thermometer in a microwave oven.
- Always read the users manual thoroughly before operating.

# Specifications

	<b>Infrared Scan</b>	<b>Thermocouple Probe</b> (K type, Grounded)
<b>Measurement Range</b>	-76 to +662°F/ -60 to +350°C	-76 to +662°F/ -60 to +350°C
<b>Operating Range</b>	32 to 122°F/0 to 50°C	
<b>Water Resilience</b>	IP54	
<b>Accuracy</b> (Tobj=59-95°F/ 15-35°C, Tamb=77°F/25°C)	±1.1 F/±0.6°C	
<b>Accuracy</b> (Tamb=73 ±37.4°F/ 23 ±3°C)	-76 to 32°F/-60 to 0°C: ±(1.8°F/1°C + 0.1/ degree C) 32 to 149°F/0 to 65°C: ±1.8°F/±1°C 149 to 662°F/ 65 to 350°C: ±1.5% of reading	below 23°F/-5°C: ±1.8°F/±1°C 23 to 149°F/-5 to 65°C: ±0.9°F/0.5°C above 149°F/65°C: ±1% of reading
<b>Distance:Spot</b>	8:1 optics ratio	
<b>Emissivity Range</b>	0.95 default; adjustable 0.1 to 1, step .01	
<b>Resolution</b> (14.18 to 392°F/ -9.9 to 199.9°C)	0.5°F/0.2°C, otherwise 1°F/1°C	
<b>Power Supply</b>	2 DC 1.5V AAA Alkaline batteries	
<b>Battery Life</b>	Typ. 18 hours, min 14 hours continuous use (alkaline, with laser) (auto power off after 15 seconds)	
<b>Dimensions</b>	2.08 W x 6.22 H x 1.55 D (inches)/ 52.9 W x 158.0 H x 39.3 D (mm)	
<b>Weight</b>	5.11 oz/145 g (including battery)	

**Note for Induction Cooktops:** Sometimes, the induction cooktop magnetic field may interfere with digital thermometers. If there is interference, briefly turn off the induction cooktop to get a digital thermometer reading or use a dial thermometer.

**CAUTION:** Avoid keeping the thermometer too close to objects that continuously generate high heat for long periods (i.e., hot plate). This can cause the thermometer to overheat.

**CE Note:** This device could be sensitive to electrostatic discharge. If electrostatic discharge or malfunctioning occurs, please re-install the battery to reset this unit.

## USDA SAFE FOOD TEMPERATURES

- \* Beef, Veal, Lamb – well . . . . 160°F . . . 71°C
- \* Beef, Veal, Lamb – medium. 145°F . . 63°C
- \* Beef, Veal, Lamb – rare . . . . 140°F . . 60°C
- Poultry. . . . . 165°F . . . 74°C
- \* Pork/Ham – pre-cooked . . . 145°F . . 63°C
- Ground Meat. . . . . 160°F . . . 71°C
- \* 3 minutes rest time

## CANDY TEMPERATURE GUIDE

- Jelly . . . . . 220°F . . . . . 104°C
- Thread. . . . . 230-234°F . . 110-112°C
- Soft Ball . . . . . 234-240°F . . 112-115°C
- Firm Ball . . . . . 244-248°F . . 118-120°C
- Hard Ball. . . . . 250-266°F . . 121-130°C
- Soft Crack. . . . . 270-290°F . . 132-143°C
- Hard Crack . . . . . 300-310°F . . 149-154°C
- Caramelize . . . . . 316-338°F . . 158-170°C

## HIGH ALTITUDE ADJUSTMENT FOR CANDY-MAKING

STAGE	2,000 feet	5,000 feet	7,500 feet
Soft Ball	230-236°F	224-230°F	219-225°F
Firm Ball	238-244°F	232-238°F	227-233°F
Hard Ball	246-264°F	240-258°F	235-253°F
Soft Crack	266-286°F	260-286°F	255-275°F
Hard Crack	296-306°F	290-300°F	285-295°F

## OIL TEMPERATURE GUIDE

325-375°F/163-190°C is the normal desired temperature for deep fry cooking.

**Note:** When food is added to hot oil, the temperature of the oil immediately drops at least 50°F/28°C. You will need to bring the oil temperature back to the desired cooking temperature. Frying at lower temperatures results in lighter color, less flavor development and increased oil absorption.

## DEEP FRY TEMPERATURE GUIDE

- Deep Fry Lo . . . . . 325-340°F . . . 163-170°C
- Deep Fry Hi. . . . . 340-365°F . . . 170-185°C
- Shrimp . . . . . 350°F . . . . . 177°C
- Chicken. . . . . 355°F . . . . . 180°C
- Onions. . . . . 370°F . . . . . 188°C
- Fish . . . . . 375°F . . . . . 191°C
- Doughnuts/Fritters . . . 375°F . . . . . 191°C
- French Fries . . . . . 380°F . . . . . 193°C



Antimicrobial properties are built-in to inhibit the growth of bacteria that may affect this product. According to EPA guidelines we cannot claim that the antimicrobial properties in this product protect users or others against bacteria, viruses, germs, or other disease organisms. This product does not protect users or

others against food-borne bacteria. Always clean and wash this product thoroughly before and after each use.

The information in this document has been reviewed and is believed to be accurate. However, neither the manufacturer nor its affiliates assume any responsibility for inaccuracies, errors or omissions that may be contained herein. In no event will the manufacturer or its affiliates be liable for direct, indirect, special, incidental or consequential damages arisen by using this product or resulting from any defect/omission in this document, even if advised of the possibility of such damages. The manufacturer and its affiliates reserve the right to make improvements or changes to this document and the products and services described at any time, without notice or obligation.



**1-Year Limited Warranty:** Any instrument that proves to be defective in material or workmanship within one year of original purchase will be repaired or replaced without charge upon receipt of the unit prepaid at: CDN, PO Box 10947, Portland, OR 97296-0947. This warranty does not cover damage in shipment or failure caused by tampering, obvious carelessness or abuse.



For more detailed information on our products, please visit [cdn-timeandtemp.com](http://cdn-timeandtemp.com).



**Component Design Northwest, Inc.**

PO Box 10947  
Portland, OR 97296-0947

Tel 800 338-5594  
Fax 800 879-2364

[info@cdn-timeandtemp.com](mailto:info@cdn-timeandtemp.com)  
[www.cdn-timeandtemp.com](http://www.cdn-timeandtemp.com)

